

DB-ALM Protocol n° 115 : Rat Skin Transcutaneous Electrical Resistance (TER) Test

Skin Irritation and Corrosivity

The corrosivity potential of a chemical may be predicted from its effects on the transcutaneous electrical resistance of rat skin and from its effects on the penetration of sulforhodamine B dye through the skin. (*Validation study protocol*)

Objective & Application

TYPE OF TESTING	: screening, replacement
LEVEL OF ASSESSMENT	: toxic potential, toxic potency
PURPOSE OF TESTING	: hazard identification, classification and labelling

The test method was granted regulatory approval as a replacement for the *in vivo* skin corrosivity test (Method B.40, EU 2000, 2008; OECD Test Guideline 430, OECD 2004) and it is used for hazard identification and classification of corrosive potential in order to fulfil the regulatory requirements concerning the Registration, Evaluation, Authorisation and Restriction of Chemicals (EU, 2008). Furthermore, the test method is recommended for its use within the context of the sequential skin corrosivity testing strategy (OECD Test Guideline 404, OECD 2002 and Method B.4, EU 2004 and 2008).

The test allows the identification of corrosive chemical substances and mixtures and enables the identification of non-corrosive substances and mixtures when supported by a weight-of-the-evidence determination using other existing information (OECD, 2004 and EU, 2008).

When used in screening mode, the TER test is employed to predict corrosivity potential rather than the degree of corrosive effect (i.e. potency) (Fentem *et al.*, 1998).

Résumé

Most international regulatory classification schemes define chemically induced dermal corrosion as full thickness destruction (necrosis) of the skin tissue, while some extend the definition of corrosion to include any irreversible alterations caused to the skin. The potential to induce skin corrosion is an important consideration in establishing procedures for the safe handling, packing and transport of chemicals.

The determination of the skin corrosion potential is therefore included in international regulatory requirements for the testing of chemicals, such as the U.S. Code of Federal Regulations (US DOT, 1991), the updated OECD Test Guideline No 404 (OECD, 2002) and the Method B.4 of the Annex to Commission Regulation 440/2008/EC (EU, 2008). Corrosivity was usually determined *in vivo* using the Draize rabbit skin test (Draize *et al.*, 1944).

The present test is based on the experience that transcutaneous electrical resistance (TER) measurements showed to be of value in predicting severe cutaneous effects *in vivo*.

In fact, the TER assay developed and evaluated by Oliver and coworkers (Barlow *et al.*, 1991; Oliver *et al.*, 1986; 1988; Oliver, 1990) has been used successfully as a routine in-house test for several years (Fentem *et al.*, 1998 and Fentem, 1999).

In addition to the changes in transcutaneous electrical resistance, a second endpoint, dye binding (sulforhodamine B), has been added for protocol optimization after the ECVAM prevalidation study, with the aim to reduce the number of false positive predictions encountered previously with surfactants and neutral organics.

Experimental Description

Endpoint and Endpoint Measurement:

VITAL DYE BINDING: dye binding (sulforhodamine B) determined by optical density measurements

TRANSCUTANEOUS ELECTRICAL RESISTANCE: Changes in transcutaneous electrical resistance (kW)

Experimental System(s):

SKIN (rat): Isolated rat skin

Basic Procedure

Liquid or solid test material is applied to the inner epidermal surface of discs of freshly isolated rat dorsal skin. After the exposure periods of 2 and 24 hours, the skin is washed and transcutaneous electrical resistance is measured. If the electrical resistance values are $<5\text{k}\Omega$ and the substance is a surfactant or neutral organic, then the sulforhodamine B dye is applied to the epidermal surface of each skin disc. The discs are washed and then subjected to a dye extraction procedure.

The amount of dye extracted is determined from optical density measurements. The changes in the endpoints are then compared to HCl and H_2O , the positive and negative controls.

Data Analysis/Prediction Model

Corrosive materials are identified by their ability to produce a loss of normal stratum corneum integrity and barrier function, which is measured as a reduction in the inherent TER below a predetermined threshold level ($5\text{k}\Omega$); non-irritant substances do not reduce the inherent TER below a predetermined threshold level.

If the transcutaneous electrical resistance readings are $\leq 5\text{k}\Omega$ at either of the contact periods, and the substance is a surfactant or neutral organic, then the dye penetration results are considered.

For detailed information see section 11, "**Interpretation of results**" of the present standard operating procedure.

Test Compounds and Results Summary

A total of 60 test compounds, consisting of 11 organic acids, 10 organic bases, 9 neutral organics, 5 phenols, 7 inorganic acids, 4 inorganic bases, 3 inorganic salts, 8 electrophiles and 3 soaps/surfactants (Barratt *et al.*, 1998) were tested in the ECVAM validation study.

Discussion

The TER assay is robust, requires inexpensive and readily available equipment, and can be performed by most laboratory personnel provided that care is taken during the critical steps of disc preparation and washing. The assay is inexpensive to perform in comparison with the three-dimensional tissue culture models and the CORROSITEX assay, and the technology is not protected by patent. These factors support the overall applicability of the TER assay in routine testing. The validation study has demonstrated the accuracy of the TER assay in identifying C and NC chemicals) (Fentem *et al.*, 1998).

Status

Participation in Evaluation Studies:

In the past, the TER assay has been evaluated in various intralaboratory and interlaboratory studies (Botham *et al.*, 1992; Oliver *et al.*, 1986, 1988).

Participation in Validation Studies:

After prevalidation (1993-1994) (Botham *et al.*, 1995), this method has been evaluated in the **ECVAM International Validation Study on *In Vitro* Tests for Skin Corrosivity** conducted from 1996 to 1997 (Fentem *et al.*, 1998).

Based on the successful outcome of the study, the ECVAM Scientific Advisory Committee (ESAC) unanimously endorsed the statement that the rat skin TER test was scientifically validated for use as a replacement for the animal test for distinguishing between corrosive and non-corrosive chemicals, and that this test was ready to be considered for regulatory acceptance (ESAC, 1998).

Regulatory Acceptance:

In 2000 the TER assay has been included into "Annex V. Part B.40 on Skin Corrosion" of the "Directive 67/548/EEC on the Classification, Packaging and Labelling of Dangerous Substances" (EU, 2000).

The test method was further recommended to be used as one of the *in vitro* methods for skin corrosivity testing in the OECD Test Guideline 404 (OECD, 2002) and in the Method B.4 of Annex V of the Directive 67/548/EEC (EU, 2004) laying down the step-wise testing strategy for classifying skin corrosives by the sequential application of three alternative methods: structure-activity relationships, pH measurements and a single *in vitro* method (Worth *et al.*, 1998).

In 2004, *In Vitro* Skin Corrosion: Transcutaneous Electrical Resistance Test was adopted as the OECD

Test Guideline No 430 (OECD, 2004).

In May 2008, all the test methods of Annex V of the Directive 67/548/EEC have been incorporated into the Annex to the Commission Regulation 440/2008/EC, laying down test methods pursuant to Regulation (EC) No 1907/2006 of the European Parliament and of the Council on the Registration, Evaluation, Authorisation and Restriction of Chemicals (REACH) (EU, 2008).

Last update: December 2008

PROCEDURE DETAILS, July 1996*

Rat Skin Transcutaneous Electrical Resistance (TER) Test DB-ALM Protocol n° 115

this protocol presents the standard operating procedure used in the ECVAM International Validation Study on In Vitro Tests for Skin Corrosivity (Fentem et al., 1998).

* The accuracy of the SOP has been confirmed in September 2000.

As of November 2007, the DB-ALM can no longer provide contact details for the author of this protocol due to unforeseen circumstances. The DB-ALM is unable to confirm the long-term on-line availability of this protocol.

1. Introduction and Objectives

The purpose of this technique is to assess the degree of the skin corrosive potential of a test chemical *in vitro*. The results obtained from the transcutaneous electrical resistance (TER) measurements are believed to be of value in predicting severe cutaneous effects (degree of skin corrosive potential) *in vivo*. As a prelude to formal validation, the TER assay was evaluated in a prevalidation study (Botham et al., 1995). Preliminary evaluation of the results indicated that the TER test required optimisation, to enable differentiation between different classes of corrosive materials, and to reduce the number of over-predictions (false positives). The results of this optimisation (Hadfield & Lewis, 1996; unpublished data), indicated that the modified electrical resistance test was able to differentiate between classes of corrosive materials (R35/R34) and, by the addition of a second endpoint, dye binding, was able to reduce the number of false positive predictions. The following protocol was therefore devised for use in the ECVAM international validation study on *in vitro* tests for skin corrosivity (Barratt et al., 1998; Fentem et al., 1998)

2. Safety Precautions

Standard local safety precautions should be adopted. All materials should be handled in accordance with their potential hazards.

3. Animals and Husbandry

20-23 day old Wistar rats are purchased for use in the test. Animals are acclimatised for a minimum of one night, depending on the day of delivery. On the day after arrival they are shaved and washed: animals are held securely and the dorsal flank hair is carefully removed with small animal clippers. The animals are then washed by careful wiping, whilst submerging the area in a one-litre volume of antibiotic solution (see section 4). Animals are washed again on the third or fourth day following the first wash, and they are then used within 3 days (animals must not be older than 31 days for pelt preparation).

4. Preparation of antibiotic solution

An antibiotic solution is prepared by adding streptomycin, penicillin, chloramphenicol and amphotericin B to 1 litre of luke-warm deionised water. The resulting antibiotic solution should contain the following concentrations: 8mgmt⁻¹ streptomycin; 800 µgml⁻¹ penicillin; 10 µgml⁻¹ chloramphenicol; and 10 µgml⁻¹ amphotericin B.

Streptomycin, penicillin, chloramphenicol and amphotericin B are

available from standard laboratory suppliers. It is also acceptable to use mixtures of antibiotics containing glutamine which are commercially available. Appropriate inhalation safety procedures should be followed when handling antibiotics.

5. Preparation of skin and mounting on IN VITRO apparatus

Animals are humanely killed by inhalation of a rising concentration of CO₂ followed by cervical dislocation. The dorsal skin of each animal is then removed and stripped of excess fat by carefully peeling it away from the skin by using the thumb and forefinger covered with paper towel. The pelt is placed over the end of a polytetrafluoroethylene (PTFE) tube ensuring that the epidermal surface is in contact with the tube. A rubber 'O' ring is press-fitted over the end of the tube to hold the skin in place, and excess tissue is trimmed away with a scalpel blade. Tube and 'O' ring dimensions are shown in Figure 3. The rubber 'O' ring is then carefully sealed to the end of the PTFE tube with petroleum jelly (or soft paraffin wax), applied with a scalpel blade. The tube is supported by a spring ("Terry") clip inside a plastic receptor chamber containing 10ml of magnesium sulphate solution (154mM; see Figure 1). The PTFE tube is uniquely numbered with a label prior to test substance application.

Skin discs of approximately 0.79cm² can be obtained from any number of animals. However, the viability of each pelt must be assessed prior to use in the test by using the following method: two discs are taken from each pelt and prepared as described above. Electrical resistance measurements are then taken for each disc (see section 7). Both discs must produce resistance values of $\geq 10k\Omega$. The two discs are then discarded and the remainder of the pelt is used in the test. If both discs fall below the 10k Ω threshold, the pelt is discarded. If one disc falls below this threshold, another is tested; if this also falls below the threshold, the pelt is discarded. If the disc produces a TER measurement of $\geq 10k\Omega$, the pelt can be used in the test.

PTFE tubes and rubber 'O' rings are available from IMS, Dane Mill, Broadhurst Lane, Congleton, Cheshire CW12 1LA, UK.

6. Test Chemical application and removal

A measured volume of liquid test material (0.15ml) is applied to the inner epidermal surface (see Figure 1). When using solid test materials, a sufficient amount of solid material is applied to the surface of the disc ensuring that the whole surface of the epidermis is covered. Deionised or distilled water (0.15ml) is then added on top of the solid material and the tubes are shaken.

Three skin discs are used for each time point per chemical. Test chemicals are applied for contact periods of 2 and 24 hours. After the required contact time, the test chemical is removed by washing with a jet of tap water, at room temperature, for approximately 10 seconds or until no further test material can be removed.

Control substances for the TER test and the dye binding assay:

Positive - 36% HCl

Negative - DH₂O

All to be tested at the 24-hour contact period only.

Test substances should have maximum contact with the skin. For some solids this may be achieved by warming up to 30°C to melt the test substance, or by grinding to produce a granular material or powder.

Where measured test substance TER values are higher than the negative (water) control values (for example, waxy solids which may become liquids at approximately room temperature), the skin surface can be washed with water at up to 37°C. The skin should be visually inspected to determine if the skin is coated with test substance. The TER value should then be re-measured. If the value is less than or equal to the upper limit of the negative (water) control range, and if the skin disc appears to be free of residue, it can be accepted. If the TER value does not reduce to the upper limit of the negative control range after washing with the warm water, the disc should be rejected.

7. Transcutaneous electrical resistance measurements

The transcutaneous electrical resistance is measured using an AIM electronic databridge 401 or 6401 (available from H. Tinsley and Co., 275 King Henry's Drive, New Addington, Croydon, Surrey CR0 0AE, UK).

Prior to measuring the electrical resistance, the surface tension of the skin is reduced by adding a small volume of 70% ethanol sufficient to cover the epidermis. After approximately 3 seconds, the ethanol is removed by inverting the tube. The PTFE tube is then replaced in the receptor chamber and the tissue is hydrated by the addition of 3ml of magnesium sulphate solution (154mM) to the inside of the PTFE tube; any air bubbles are dislodged by slight tapping.

The stainless steel electrodes of the databridge are then placed on either side of the skin disc to take the resistance measurement in kW/skin disc (see Figure 2). Electrode dimensions and the length of the electrode exposed below the crocodile clips are shown in Figure 3. The inner (thick) electrode clip is rested on the top of the PTFE tube during resistance measurement, to ensure that a consistent length of electrode is submerged in the MgSO₄ solution. The outer (thin) electrode is positioned inside the receptor chamber, so that it rests on the bottom of the chamber. The distance between the bottom of the Terry clip and the bottom of the PTFE tube is set at 7.0cm, to reduce the variability of resistance measurements between individual skin discs, which is influenced by the distance between the electrodes. The electrical resistance is then recorded from the databridge display.

If the reading falls above 20kW this may be due to the test material coating the epidermal surface of the skin disc. Removal of this coating can be performed by holding a gloved thumb over the end of the tube and shaking it for approximately 10 seconds; the MgSO₄ solution is then poured away. If any test material is present it may be seen as a residue in the MgSO₄ solution. The transcutaneous electrical resistance of the skin is then measured as described previously.

8. Sulforhodamine B dye application and removal

If the electrical resistance values are \leq 5kW at the 2- and/or 24-hour contact periods, an assessment of dye penetration is carried out on the 24-hour contact period tissues. If the skin disc was punctured during the jet washing procedure to remove the test chemical, then that particular tube is excluded from further testing.

150 μ l of a 10% (w/v) dilution of sulforhodamine B dye in DH₂O is applied to the epidermal surface of each skin disc for 2 hours. To remove any excess/unbound dye, the skin discs are then jet-washed with tap water at room temperature for approximately 10 seconds (or

until the water runs clear). Each skin disc is carefully removed from the PTFE tube and placed in a 20ml scintillation vial containing 8ml of deionised water.

The vials are agitated gently for 5 minutes to remove any further excess/unbound dye. This rinsing procedure is then repeated. Each skin disc is removed and placed into another 20ml scintillation vial containing 5ml of 30% (w/v) sodium dodecyl sulphate (SDS) in D₂O and is incubated overnight at 60°C.

After incubation, each skin disc is removed and discarded and the remaining solution is centrifuged in a 15ml centrifuge tube at 1000rpm for 8 minutes at 21°C (relative centrifugal force ~ 175g). A 1ml sample of the supernatant is then placed into another 15ml centrifuge tube and diluted 1 in 5 (v/v) (i.e. 1ml + 4ml) with 30% (w/v) SDS in D₂O. The optical density of the solution is determined at 565.5nm and the results are recorded.

Sulforhodamine B (90% dye content) and SDS are available from Sigma Chemical Company, Poole, UK.

9. Further information

Experience with the TER assay has shown that there are two critical stages. Experienced users pay particular attention to: a) skin disc preparation, ensuring removal of all fatty tissues and a complete seal of the skin on the PTFE tube; b) washing of the disc to remove as much of the test substance as possible. Residues of test substance remaining on the skin may affect the resistance values (for example, waxy substances which solidify on the skin's surface).

The positive controls TER values can drift with time (within days) if the samples are not fresh aliquoted from the stock acid maintained according to the storage recommendations on the label.

10. Calculation of dye content/disc

The dye content, in µg/disc, is calculated from the optical density values as follows:

Sulforhodamine B dye molar extinction coefficient = 8.7×10^4 ;
Molecular Weight= 580.

No correction for the purity of the dye is made.

Optical density = 0.973

$$\frac{0.973 \times 10^{-4}}{8.7} = 0.112 \times 10^{-4} = 11.2 \times 10^{-6} = 11.2 \mu M = 11.2 \mu mol/l$$

$$11.2 \times 580 \times 10^{-6} = 6496 \times 10^{-6} g/l = 6.496 \times 10^{-3} g/l$$

Dye was extracted into 5ml of solvent:

$$\frac{6.496 \times 10^{-3}}{200} = 0.325 \times 10^{-4} g/l = 32.5 \times 10^{-6} g/l$$

Solution was diluted 1 in 5 (v/v):

$$32.5 \times 10^{-6} \times 5 = 162.5 \times 10^{-6} = 162.5 \mu g/disc$$

The sulforhodamine B dye content is determined for each skin disc. A mean dye content is then calculated for the three skin discs at 24 hours.

If a skin disc is punctured during the washing procedure used to remove the dye, then the individual dye content is recorded but it is excluded from the calculation of the mean.

All results are recorded on the data sheet shown in Appendix 1.

11. Interpretation of results

a) Results are accepted on condition of adherence to the ranges given below. If the positive and negative control results for the experiment do not fall within the accepted ranges, the data on the test substance cannot be interpreted and the experiment must be repeated.

Dye binding assay		TER assay	
36% HCl positive control range ($\mu\text{g}/\text{disc}$) 40 - 100	Distilled water negative control range ($\mu\text{g}/\text{disc}$) 15 - 35	36% HCl positive control range (kW) 0.5 - 1.0	Distilled water negative control range (kW) 10 - 25

b) If the transcutaneous electrical resistance readings obtained for all test substance contact periods are $> 5\text{kW}$, then the substance is classified as **non-corrosive**.

c) If the transcutaneous electrical resistance readings are $\leq 5\text{kW}$ after a 2-hour contact period, and the substance is not a surfactant or neutral organic, then the substance is classified as **corrosive** (R35).

d) If the transcutaneous electrical resistance readings are $\leq 5\text{kW}$ after a 24-hour contact period (but $>5\text{kW}$ after 2 hours contact), and the substance is not a surfactant or neutral organic, then the substance is classified as **corrosive** (R34).

e) If the transcutaneous electrical resistance readings are $\leq 5\text{kW}$ at either of the contact periods, and the substance is a surfactant or neutral organic, then the dye penetration results are considered.

f) If the mean disc dye content is \geq mean disc dye content of the 36% HCl positive control obtained concurrently in the experiment at the 24-hour contact period, then the substance is a true positive and is therefore classified as **corrosive** (R34).

g) If the mean disc dye content is $<$ mean disc dye content of the 36% HCl positive control obtained concurrently in the experiment at the 24-hour contact period, then the substance is a false positive and is therefore classified as **non-corrosive**.

A flow diagram for interpretation of the results is attached.

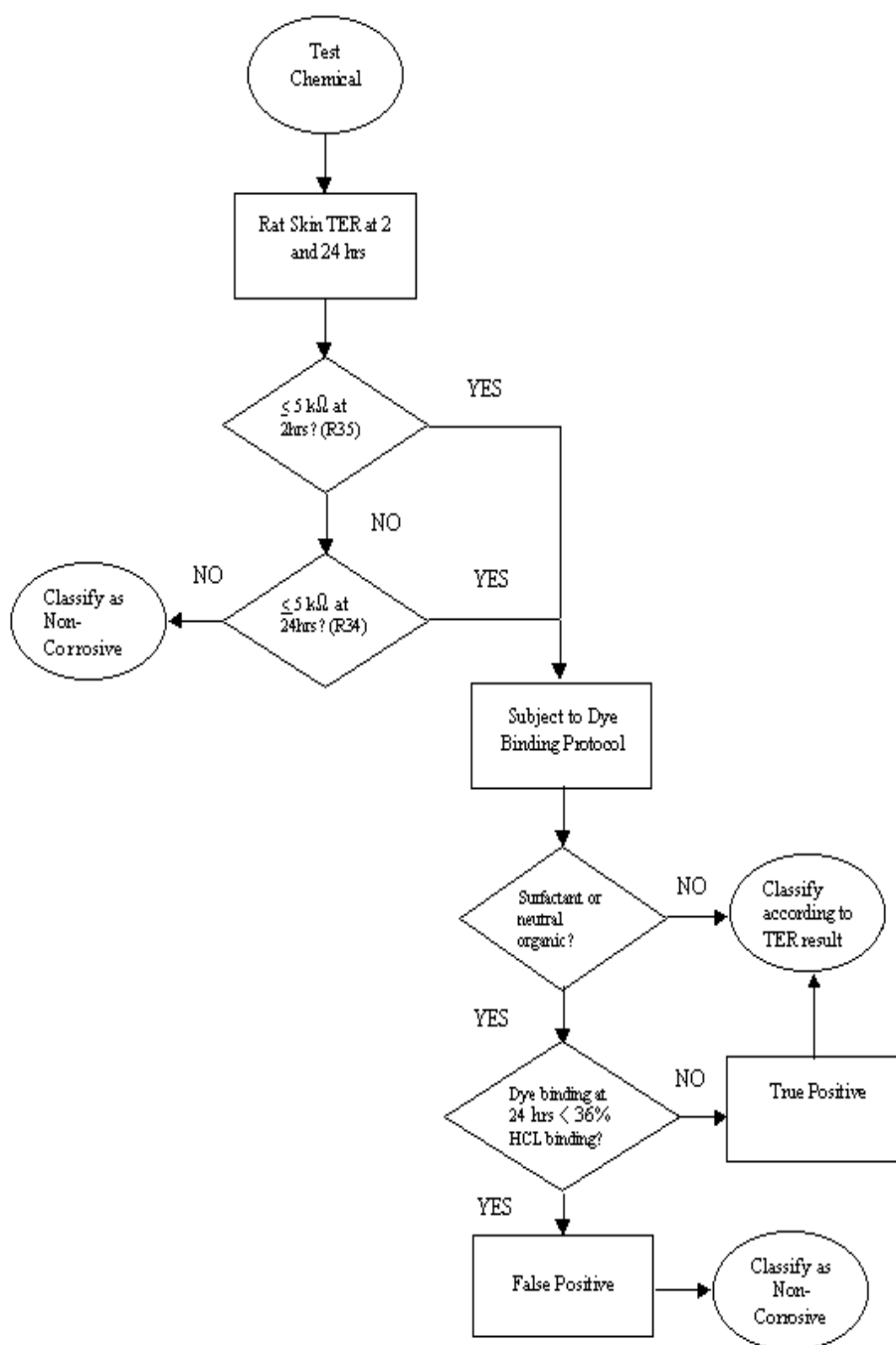

Figure 1

In Vitro Skin Corrosivity Model

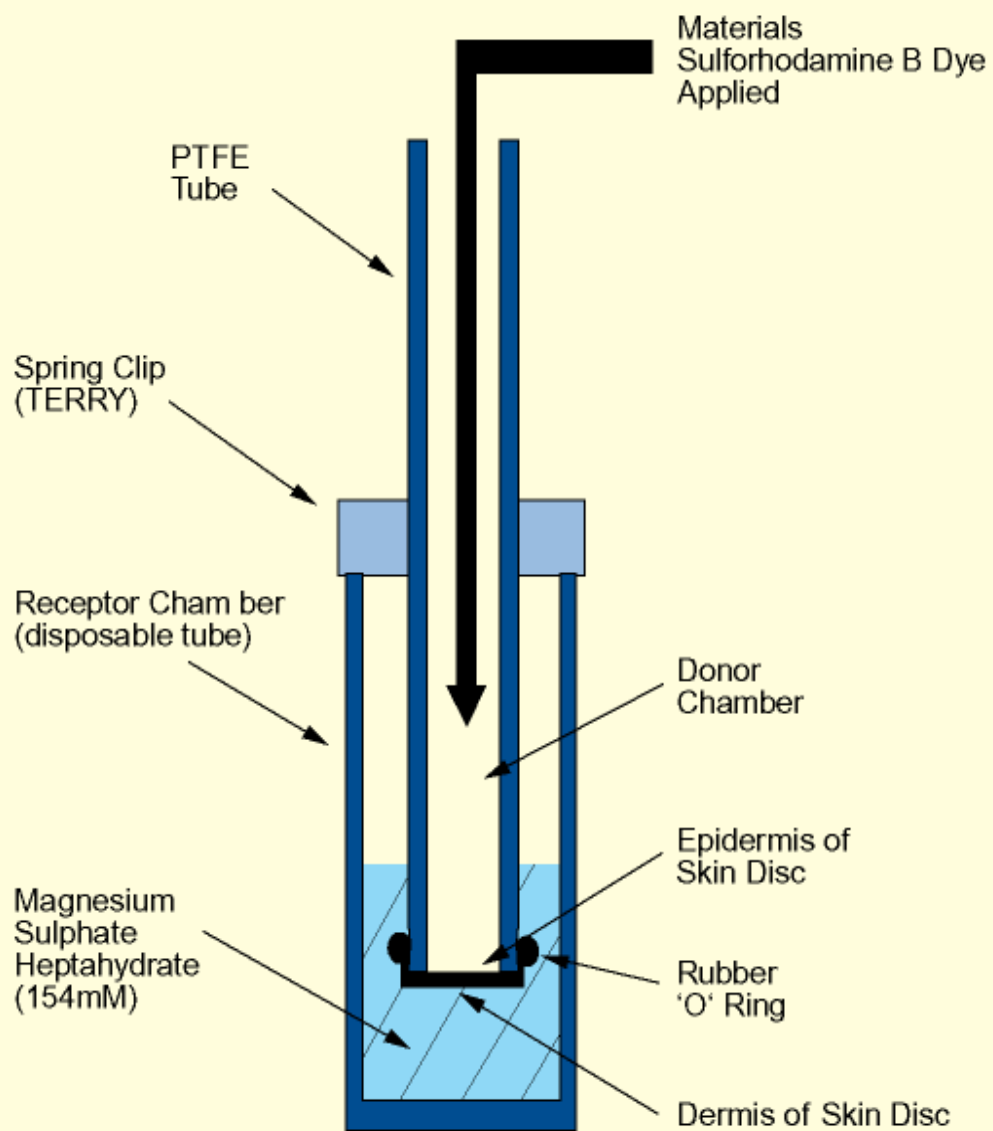

Figure 2

In Vitro Skin Corrosivity Model

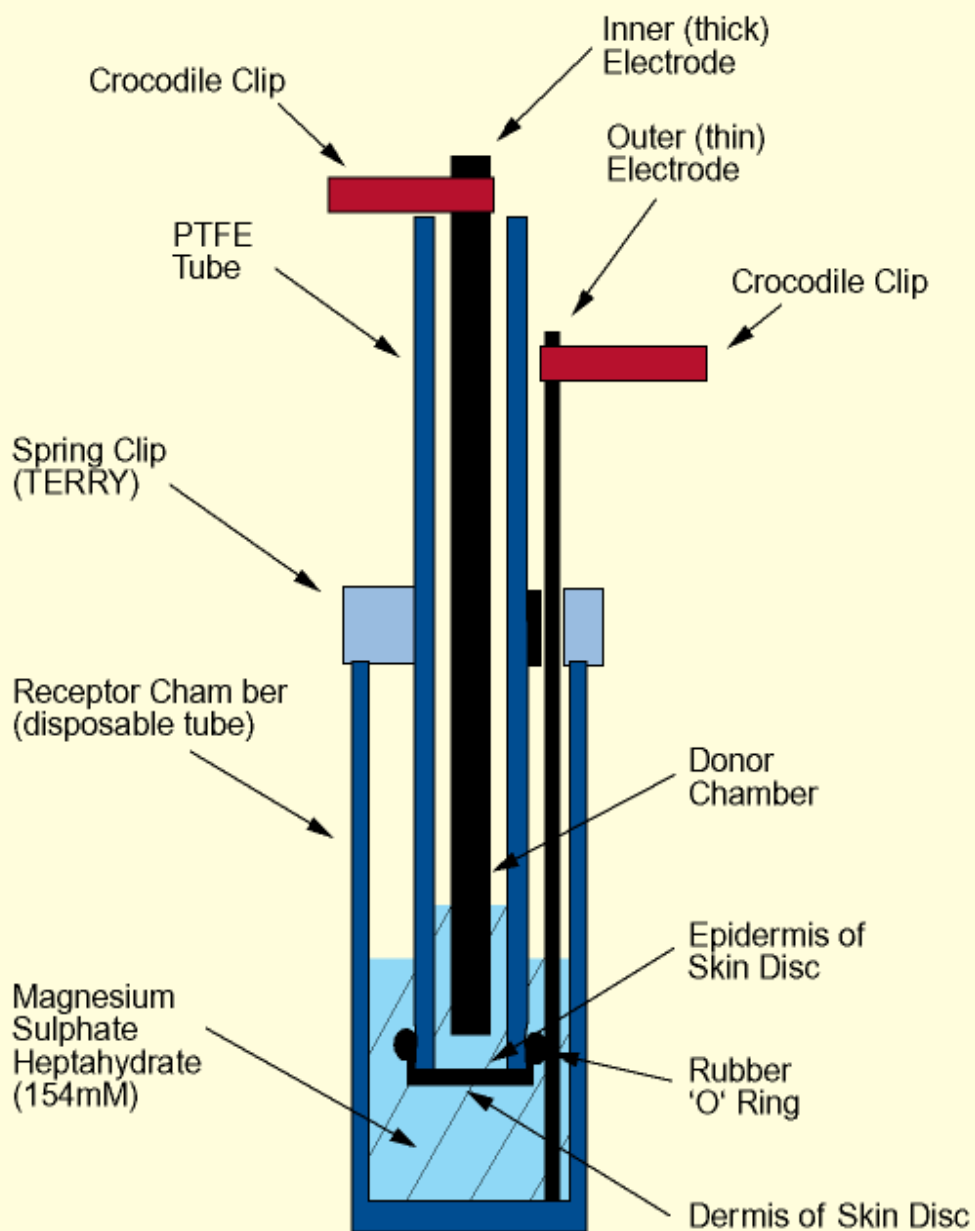
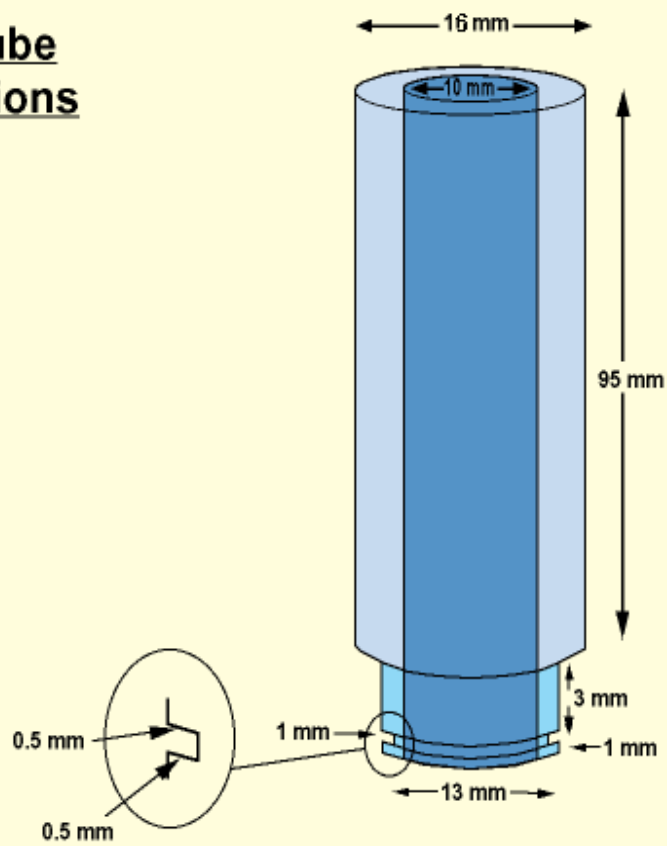
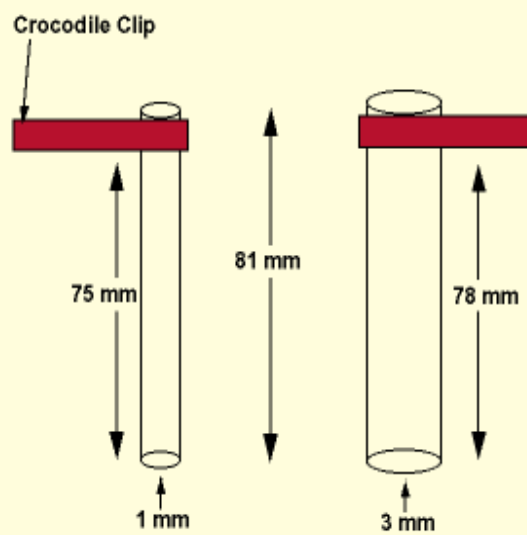

Figure 3

PTFE Tube Dimensions



Electrode Dimensions



APPENDIX 1: ECVAM Validation Study

Transcutaneous Electrical Resistance Test/Dye Binding - Results Summary Sheet

Laboratory Study Number: _____ Laboratory Name: _____ Experiment Number: _____

Test Chemical and appearance	Contact Time (hours)	Tissue number	Electrical Resistance (kOhms)	Mean T.E.R. ± S.D. (kOhms)	
	2				
	24				

Dye Contact Time (hours)	Optical Density at 586.5 nm (diluted 1 in 5)	Dye Concentration (µg/disc)	Mean Dye Concentration ± S.D. (µg/disc)	36% HCL Positive Control Mean Dye Concentration ± S.D. (µg/disc)	Classification
2					R36
					R34
					NC
					PG I
					PG II/III
					NC

Signature: _____ Date: _____

Checked by: _____ Date: _____

Bibliography

- Barlow A., Hirst R.A., Pemberton M.A., Rigden A., Hall T.J., Botham P.A. and Oliver G.J.A. (1991) Refinement of an *in vitro* test for the identification of skin corrosive chemicals. *Toxicology Methods* 1, 106-115
- Barratt M.D., Brantom P.G., Fentem J.H., Gerner I., Walker A.P. and Worth A.P. (1998) The ECVAM international validation study on *in vitro* tests for skin corrosivity. 1. Selection and distribution of the test chemicals.

Toxicology In Vitro 12, 471-482

- Botham P., Chamberlain M., Barret M. D., Curren R.D., Esdaile D.J., Gardner J.R., Gordon V.C., Hildebrand B., Lewis R.D., Liebsch M., Logemann P., Osborne R., Ponc M., Régnier J.-F., Steiling W., Walker A.P. and Balls M. (1995)
A prevalidation study on in vitro skin corrosivity testing. The Report and Recommendations of ECVAM Workshop 6.
Alternatives to Laboratory Animals (ATLA) 23, 219-255
- Botham P.A., Hall T.J., Dennett R., McCall J.C., Basketter D.A., Whittle E., Cheeseman M., Esdaile D.J. and Gardner J. (1992)
The skin corrosivity test in vitro: results of an interlaboratory trial.
Toxicology In Vitro 6, 191-194
- Draize J.H., Woodard G.K. and Calvery H.O. (1944)
Methods for the study of irritation and toxicity of substances applied topically to the skin and mucous membranes.
Journal of Pharmacology and Experimental Therapeutics 82, 377-390
- ESAC (1998)
Statement on the scientific validity of the rat skin transcutaneous Electrical resistance (TER) test (an *in vitro* test for skin corrosivity), 10th meeting of ECVAM Scientific Advisory Committee, 31 March 1998, European Commission-Joint Research Centre, Institute for Health and Consumer Protection, European Centre for the Validation of Alternative Methods (ECVAM), Ispra, Italy. ECVAM News and Views.
Alternatives to Laboratory Animals (ATLA) 26, 275-280
- EU (2008)
Council Regulation (EC) No 440/2008 of 30 May 2008, laying down test methods pursuant to Regulation (EC) No 1907/2006 of the European Parliament and of the Council on the Registration, Evaluation, Authorisation and Restriction of Chemicals (REACH). Annex, part B. Methods for the determination of toxicity and other health effects.
Official Journal of the European Communities L 142, 141-443
- EU (2004)
Commission Directive 2004/73/EC of 29 April 2004, adapting to technical progress for the 29th time Council Directive 67/548/EEC on the approximation of laws, regulations and administrative provisions relating to the classification, packaging and labelling of dangerous substances.
Official Journal of the European Communities L 152, 1
- EU (2000)
Commission Directive 2000/33/EC of 25 April 2000, adapting to technical progress for the 27th time Council Directive 67/548/EEC on the approximation of laws, regulations and administrative provisions relating to the classification, packaging and labelling of dangerous substances.
Official Journal of the European Communities L 136, 90
- Fentem J.H. (1999)
Validation of *in vitro* tests for skin corrosivity.
Alternatives to Animal Experimentation (ALTEX) 16, 150-153
- Fentem J.H., Archer G.E.B., Balls M., Botham P.A., Curren R.D., Earl L.K., Esdaile D.J., Holzhütter H.G. and Liebsch M. (1998)
The ECVAM international validation study on *in vitro* tests for skin corrosivity. 2. Results and evaluation by the Management Team.
Toxicology In Vitro 12, 483-524
- OECD (2015)
OECD Test Guideline No. 404: Acute Dermal Irritation/Corrosion. First adopted in 1981. Latest update adopted on the 28th of July 2015. [Link to document](#) (last access: 16.06.2016)
OECD Guidelines for the Testing of Chemicals, Section 4, Health Effects
- OECD (2004)
OECD Test Guideline No. 430: *In Vitro* Skin Corrosion: Transcutaneous Electrical Resistance Test, adopted on the 13th of April 2004.
OECD Guidelines for the Testing of Chemicals, Section 4, Health Effects
- Oliver G.J.A. (1990)
The evaluation of cutaneous toxicity: past and future.
Skin Pharmacology and Toxicology: Recent Advances, 147-173
- Oliver G.J.A., Pemberton M.A. and Rhodes C. (1988)

An in vitro model for identifying skin corrosive chemicals. Initial validation.

Toxicology In Vitro 2, 7-17

- Oliver G.J.A., Pemberton M.A. and Rhodes C. (1986)
An in vitro skin corrosivity; modifications and validation.
Food and Chemical Toxicology 24, 507-512
- US DOT (1991)
U.S. Department of Transportation. Code of Federal Regulations. Method of Testing Corrosion to the Skin.
Transportation Title 49, Part 173.136, Appendix A
- Worth A.P., Fentem J.H., Balls M., Botham P.A., Curren R.D., Earl L.K., Esdaile D.J. and Liebsch M. (1998)
An evaluation of the proposed OECD testing strategy for skin corrosion.
Alternatives to Laboratory Animals (ATLA) 26, 709-720